

# Interference Avoidance Dynamic Adaptive OFDM using a Reconfigurable Radio Platform

Keith E. Nolan, Linda Doyle, Philip Mackenzie<sup>†</sup> and Donal O'Mahony

Centre for Telecommunications Value-Chain-Driven Research (CTVR)

Trinity College, Dublin, Rep. of Ireland

Telephone: (+353) 1-6088443

Fax: (+353) 1-6083998

Email: keithnolan@mee.tcd.ie

<sup>†</sup>Networks and Telecommunications Research Group (NTRG)

Trinity College, Dublin

Dublin, Rep. of Ireland

**Abstract**—This paper presents an advanced wireless communications system using an enhanced version of Orthogonal Frequency Division Multiplexing (OFDM)/Adaptive OFDM (OFDMA) called Dynamic Adaptive OFDM (DAOFDMA). The main focus of this work is the creation of a receiver-centric improved OFDM wireless transmission system that has a reduced Bit Error Rate (BER) and increased channel capacity usage in interference-prone wireless bands. This scheme dynamically adapts to the time-varying communications channel and avoids carrier frequencies experiencing interference levels in excess of a specific power-spectral density threshold level without incurring extra transmission overheads. A reconfigurable radio based on a General-Purpose Processor (GPP) platform forms the basis for this system. An analysis of the capacity enhancements and BER performance of this system in an interference and noise-affected channel model is presented.

**Index Terms**—OFDM, Adaptive OFDM, Multi-user wireless communications, sub-carrier allocation, reconfigurable software radio, quasi-realtime, enhanced radio server, general-purpose processor.

## I. INTRODUCTION

Orthogonal Frequency Division Multiplexing (OFDM) [1] [2] is a multi-carrier modulation technique and uses closely spaced orthogonal carriers that do not interfere with each other. Unlike single-carrier transmission systems, OFDM does not require complex channel equalisation techniques due to the relatively small bandwidth of each OFDM sub-carrier. OFDM is used for many popular Wireless Local Area Network (WLAN) and digital broadcasting applications including the IEEE 802.11a/g [3] [4], IEEE 802.16 [5] [6] HIPERLAN II [7] WLAN standards, Digital Video Broadcasting-Terrestrial (DVB-T) [8], Digital Audio Broadcasting (DAB) [9] and Digital Radio Mondiale (DRM) [10]. Used in a shared/license-exempt spectrum allocation, OFDM may be subject to interference from other transmission sources. This interference results in a degradation of one or more sub-carrier channels and

raises the BER of the received information. Present OFDM implementations use all of the possible sub-carriers regardless of the individual sub-carrier channel activity and interference levels, which is not necessarily an optimal solution. The first objective of the proposed dynamic sub-carrier allocation scheme is to maximise channel capacity usage by avoiding interference-affected sub-carriers and use a higher-order modulation scheme on sub-carriers not affected by excessive levels of interference. These unaffected sub-carriers can support a higher bit-to-symbol ratio, with a lower BER than sub-carriers affected by strong interference. The second main objective of this scheme therefore, is to reduce the overall BER of the received data even when the band of interest is experiencing strong interference on several sub-carriers. The third main objective is to minimise the extra transmission overheads required to notify the destination transceivers of the current sub-carrier allocation. The solution presented in this paper fulfills all three objectives.

Sub-carrier allocation research has mainly concentrated on transmitter-centric approaches where the task of informing the destination transceiver relies on using either an alternative back-channel or a set of dedicated sub-carriers. The proposed approach focuses on a receiver-notification method that does not require a dedicated channel or alternative return-path. This method does not require extra transmission overheads resulting in a reduction of the data capacity of OFDM frames. Essential OFDM-related receiver synchronisation tasks such as frame synchronisation and carrier-frequency offset estimation are incorporated into the receiver notification process, which involves the use of a single OFDM training symbol.

Wireless channel adaptation forms the basis for a cognitive radio where the benefits of wireless channel adaptation can be exploited by providing users with a choice of transmission protocols and services. The wireless system encapsulating this transmission technique is called a Multiple User Data-Enhanced Radio Server (MUDERS) [11] and the technique proposed in this paper is a further development and enhancement of this work. Figure 1 illustrates the concept of the

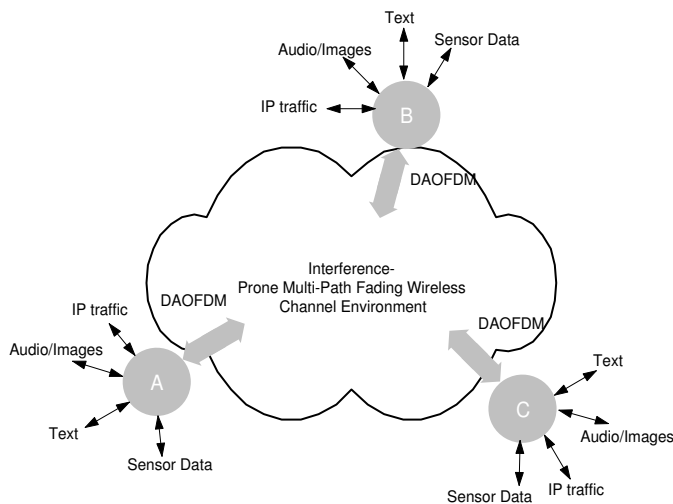

Fig. 1. Overview of three (fixed, nomadic or mobile) dynamically reconfigurable MUDERS system wireless nodes used in an interference-prone multi-path fading wireless channel environment.

MUDERS system being used in a distributed wireless network scenario where several data types are required to be conveyed between one or more other associated devices over a wireless channel affected by strong interfering signals. The radio devices automatically detect and avoid interfering carriers. This technique addresses the issue of dynamic spectrum allocation for decreased BER in interference-prone frequency bands and greater data throughput over interference-affected wireless channels. One main advantage of this transmission technique is that no increase in transmission-overheads is required and the normal data-bearing capacity of each OFDM frame remains unaffected.

### A. MUDERS structure

Apart from the essential RF and analogue/digital conversion hardware, the entire MUDERS system is implemented in software operating on a GPP platform. The underlying software structure and control mechanism used for the MUDERS system is called Implementing Radio In Software (IRIS) designed by Mackenzie and the Networks and Telecommunications Research Group (NTRG) [15] [16]. IRIS is a reconfigurable software radio implementation designed to support creative reconfigurable radio applications on an Intel x86 GPP platform. Figure 2 illustrates the main constituent components of the IRIS system. An inventory of software radio components may be structured to form a particular radio application using a configuration controller interface. Radio management and reconfiguration is achieved using the IRIS radio engine. The physical RF front-end hardware comprises a Peripheral Component Interconnect (PCI) radio module with digital In-phase (I) and Quadrature (Q) signal inputs and outputs.

IRIS uses dynamically loadable software 'components' in the form of Dynamic Link Libraries (DLLs) that may be structured to form a particular transceiver application using an eXtensible Markup Language (XML) interface to describe

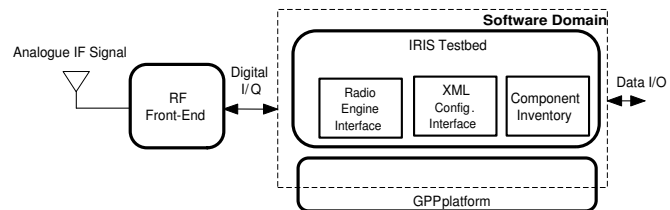

Fig. 2. Overview of the IRIS system used to implement the MUDERS reconfigurable radio application.

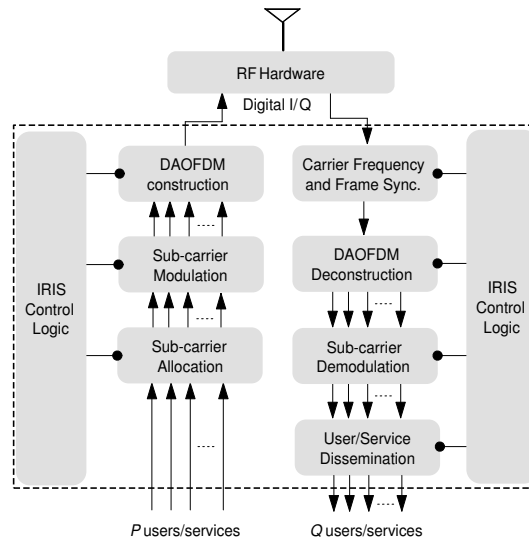

Fig. 3. Basic overview of the MUDERS design using the IRIS development testbed where  $P$  user or service data sequences are multiplexed and transmitted and  $Q$  user or service data sequences are received. The transceiver structure and component parameters are reconfigurable using external IRIS control logic.

the radio application. As the core of the MUDERS system is not bounded by physical-circuitry constraints (excluding the RF and signal-conversion hardware), it is therefore possible to create an amorphous radio structure bounded by only physical memory and processing-speed constraints.

An outline of the MUDERS system implementation, which is designed with maximum user and wireless channel reconfigurability options in mind, is shown in Figure 3. The software entities of the system are encapsulated in the dashed-line box in this diagram. The core processes of the transceiver operation are segmented into a series of software components created as DLLs using a high-level programming language (e.g. C++). The use of a GPP platform enables the designer to implement a highly-reconfigurable transceiver system due to the ease of design, implementation and significantly large amounts of available user-memory compared to traditional dedicated Digital Signal Processor (DSP) implementations. The MUDERS structure is created using an XML configuration file, which is parsed by the IRIS engine. The IRIS engine then obtains the required radio components from an inventory of available components and subsequently instantiates the software radio accordingly.

## II. SUB-CARRIER ALLOCATION

Sub-carrier allocation is a means of dynamically assigning carrier frequencies for the conveyance of data to/from one or more wireless devices. Selective sub-carrier assigning techniques has also been used to transmit one or more information sequences based on the quality of the wireless channel associated with these carrier frequencies and/or the data rate/quality of service required by the users [12]. The emphasis is placed on maximising the number of sub-carriers that may be used for information transmission with a high probability that the transmitted information will be successfully received by the remote reconfigurable OFDM transceivers. In addition, the per-carrier data rate is maximised depending on the estimated channel gain associated with each carrier. This is in order to maximise the total aggregate data-throughput in a bid to progress towards the optimal 'water-pouring' bit and power allocation solution [13] [14]. In order to intelligently assign sub-carriers for transmission of one or more information sources, a means of gauging the current level of spectral-activity and individual channel gains within a frequency band of interest is required.

Sub-carrier allocation may be viewed as separate or a combination of regions of spectrum-allocation activity. The first region is a *spectrum-driven* allocation process. In this case, sub-carriers may be assigned to transmit and receive data using specific frequencies based on current spectrum availability derived from information relating to the current or historic wireless channel activity or by the network controller. The second region of carrier allocation activity, denoted *application-driven* spectrum allocation, is driven by the particular user and/or application that requires access to the wireless spectrum segment without taking account of the current wireless activity present on the selected carrier frequencies. The third allocation activity region is a combination of both the application-driven and spectrum-driven approaches called *application and spectrum-driven* sub-carrier allocation where an wireless application demands a specific number of sub-carriers to maintain a desired quality of service (QoS) based on the current availability of sub-carriers. The application in this case is driven by the wireless device user's transmission requirements. The proposed technique tackles this third region of spectrum-allocation capabilities and is designed to facilitate combined application and wireless channel-driven spectrum allocation.

The adaptive nature of this wireless transmission system requires a flexible approach to the radio design instead of a fixed-architecture all-hardware realisation. The main reason for this is that the signal-processing chain and parameters used for one or all of the individual radio component blocks may be modified continuously due to the time-varying characteristics of the wireless channel. In fact, air-interface reconfigurability is a valuable asset of reconfigurable radios, enabling the transmitter to avoid sub-carrier frequencies occupied by another user, take advantage of, or limit frequency usage for spectrum sharing/pooling applications.

In order to implement reconfigurable spectrum allocation techniques, software implementations afford the greatest level of flexibility of algorithmic change and adaptability compared to fixed-architecture hardware instances. Spectrum allocation techniques are predominately focussed on improving communications over increasingly congested frequency bands by increasing the amount of information that may be received across a wireless channel with a low BER. The MUDERS system described in this paper uses parameter-level reconfiguration for sub-carrier allocation.

### A. Sub-carrier Allocation Process

Consider an OFDM transceiver system with  $N_{SC}$  useful sub-carriers used for transmission, using a FFT of length  $N_{FFT}$ . An OFDM symbol is a multiplex of orthogonal sub-carriers, created in the frequency-domain initially and then converted to a time-domain waveform using the Inverse Fast Fourier Transform (IFFT). A data symbol is a point on a constellation diagram of a chosen modulation scheme that represents a modulated grouping of one or binary values depending on the specific modulation scheme. A modulation scheme such as 16-QAM may represent a grouping of four binary values as one data symbol. Each sub-carrier value comprised one complex-valued data symbol. The OFDM signal samples,  $x(n)$  are generated at base-band by performing an Inverse Fast Fourier Transform (IFFT) on the complex-valued sub-symbols,  $X(k)$  as follows:

$$x(n) = \frac{1}{N_{FFT}} \sum_{k=0}^{N_{FFT}-1} X(k) \exp \left\{ j2\pi \frac{nk}{N_{FFT}} \right\} \quad (1)$$

A guard interval is formed by cyclically extending the last  $N_{GI}$  samples of the OFDM symbol, where  $N_{GI}$  denotes of the length of the guard interval. If this guard interval is longer than the coherence bandwidth of the channel, the possibility of Inter-Symbol Interference (ISI) may be minimised. Prior to demodulation of an intercepted digitised OFDM baseband waveform, this guard interval is removed and the waveform is de-multiplexed by performing a FFT on the truncated received OFDM symbol,  $y(n)$ . The value  $y(n)$ , is the value of the  $k^{th}$  sub-carrier after the FFT process (i.e. the data symbol associated with this sub-carrier may be expressed as:

$$Y(k) = \sum_{n=0}^{N_{FFT}-1} y(n) \exp \left\{ -j2\pi \frac{nk}{N_{FFT}} \right\} \quad (2)$$

The *spectrum-driven* element of the sub-carrier allocation process uses information relating to the time-averaged Power Spectral Density (PSD) or periodogram of the received band of interest. The FFT operation is already an integral part of the OFDM receiver process, therefore obtaining the PSD of the received band of interest does not result in a significantly increased processing time demand on the MUDERS reconfigurable radio. The PSD,  $P(k)$ , is obtained by further processing of  $Y(k)$  in Eq. 2 to form:

$$P(k) = |Y(k)|^2 = \left| \sum_{n=0}^{N_{FFT}-1} y(n) \exp \left\{ -j2\pi \frac{nk}{N_{FFT}} \right\} \right|^2 \quad (3)$$

A binary data sequence is converted to  $N$  parallel subsets of the sequence, where  $N$  is the number of sub-carriers available for transmission. For the MUDERS DAOFDN scenario, multiple unique input data sequences are converted into  $N_{SS}$  data sequence subsets, where  $N_{SS} = \frac{N_{SC}}{N_{SRV}}$  denotes the number of available sub-carriers for transmission and  $N_{SRV}$  denotes the number of unique information sources (users) that require access to the wireless spectrum. Each sub-carrier may then transmit the information contained in each sub-set and all of the sub-carriers may be transmitted in unison resulting in significantly greater data rates than single-carrier systems.

An OFDM frame is a sequence of OFDM symbols, where each OFDM symbol is the time-domain representation of the multiplexed sub-carriers following the Inverse Fast Fourier Transform (IFFT) stage in the transmitter. The OFDM frame therefore consists of a sequence of  $N$  OFDM symbols preceded by a frame guard. This frame guard is longer than the guard-interval between two successive OFDM symbols and may be used for receiver synchronisation. One of the main issues with multi-carrier modulation methods is that multipath, flat fading, noise and/or interference may result in the unrecoverable loss of the information associated with one or more sub-carriers. Block-interleaving techniques reduce this risk but this paper proposes a dynamic spectrum allocation scheme that offers to reduce the possibility of information loss even further using a carrier-avoidance spectrum allocation technique.

### B. Receiver Notification

In order to achieve regular updates of the channel PSD, the MUDERS system relies on a *listen and update PSD history* cycle which means that the local receiver measures the PSD of the wireless channel following OFDM frame transmission and updates the PSD. This PSD information is then used to update the sub-carrier allocation. An improvement in performance may be achieved by only updating those carriers which were not-previously allocated due to previous PSD values above the PSD threshold. As shown in Figure 4, sub-carriers with a PSD greater than a this threshold value,  $P_{thresh}$ , are not used for transmission of a the subsequent OFDM frame as the high PSD may indicate that either noise, interference or other transmissions are currently occupying that particular sub-carrier. By analysing the PSD of all of the possible sub-carriers before an OFDM frame is transmitted, a sub-set of sub-carriers, where the PSD associated with each sub-carrier is less than  $P_{thresh}$  may be compiled. These valid sub-carriers may then be compiled to form a channel-mask. Emphasis is placed on maximising the number of sub-carriers that are may be employed to convey information. As a result of this, the sub-carriers which were not previously allocated due to a PSD value above the threshold value,  $P_{thresh}$  are monitored and

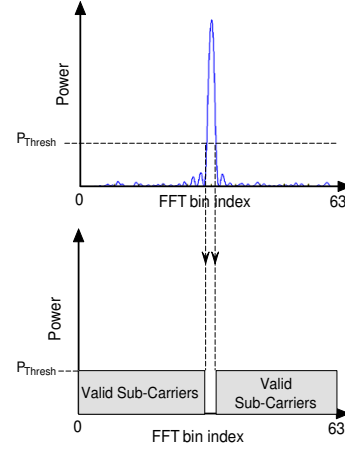

Fig. 4. Sub-carrier allocation using the Power Spectral Density (PSD) of the received channel bandwidth

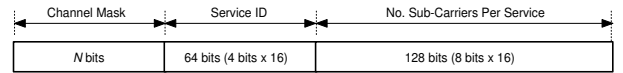

Fig. 5. Structure of the pilot frame used in the Enhanced Training Symbol

may be subsequently included in the active OFDM multiplex if  $P(k) > P_{thresh}$ , where  $P(k)$  is the power spectral density associated with the  $k^{th}$  sub-carrier.

A channel mask is created, which defines the sub-carriers used for transmission and the individual sub-carrier allocation per multiplexed user. This mask consists of a binary array where each binary value corresponds to one sub-carrier index. The size of the spectrum mask is directly proportional to the total number of sub-carriers that may be used for transmission. One binary value is assigned to each of the sub-carriers, where the maximum number of sub-carriers is equal to  $\frac{N_{FFT}}{2}$ .

Therefore, if a 128-bin FFT is used for example, the total number of sub-carriers that may be used for transmission including the zero frequency (DC) term is 64. If a sub-carrier is deemed unusable due to the previously mention PSD threshold criterion, a binary zero is stored in the channel mask array position corresponding to the index of the sub-carrier in question. A binary one in any of the channel mask array positions, as shown in Figure 5, denotes that the subcarrier associated with this array position is available for data transmission. The set of available sub-carriers is then obtained by AND-ing the array of FFT-bin indices with the channel mask.

An Enhanced Training Symbol (ETS) is formed by modulating the channel mask and creating two identical half-OFDM symbols. A high-order modulation scheme such as 16-QAM is used both to accommodate the channel mask information and to serve as a high-power pilot symbol. This ETS is transmitted during the normally null signal frame guard between OFDM frames in order to avoid reducing the data-capacity of the OFDM frames resulting from extra transmission overheads. Upon receiving this ETS, the receiver achieves frame syn-

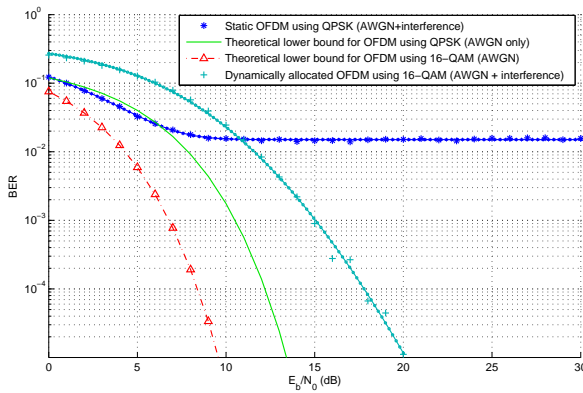

Fig. 6. BER vs  $E_b/N_0$  for uncoded static OFDM using QPSK on all possible sub-carriers and uncoded Dynamic OFDM using 16-QAM on valid carriers in an AWGN channel model affected by random multiple sub-carrier interference sources. The lower-bound  $E_b/N_0$  for uncoded QPSK and 16-QAM over an AWGN channel (without interference) are also shown.

chronisation by monitoring the received signal stream for an OFDM symbol with two identical halves using a correlation technique based on work by Schmidl and Cox [18] [17]. Known pilots inserted into the ETS aid carrier frequency offset estimation at the receiver. The receiver obtains the current sub-carrier allocation information by then demodulating this received ETS. Each channel mask is valid for one OFDM frame.

### III. EVALUATION

A baseband channel model is used to evaluate the performance of the interference-avoidance dynamic OFDM technique. The AWGN channel model is affected by a strong interfering FM transmission common to both source and destination MUDERS transceivers. Two scenarios are examined. The first scenario chosen is a static implementation of OFDM using QPSK as the sub-carrier modulation technique and all possible sub-carriers are employed. The second scenario employs the interference-avoidance sub-carrier allocation technique using 16-QAM on valid sub-carriers. Four contiguous sub-carriers are deemed unusable due to this interference. A graph of the BER vs  $E_b/N_0$  for both scenarios is shown in Fig. 6, where the lower-bound graphs for QPSK and 16-QAM for interference-free AWGN channels are also displayed. The BER of the static QPSK case remains above  $10^{-2}$  due to the interference yet the BER of the dynamically allocation 16-QAM case reaches  $10^{-5}$ . The increase in number of correctly received bits for the dynamically-allocated 16-QAM case approaches approximately double that of the static QPSK case as the SNR increases.

### IV. CONCLUSION

This paper has presented an interference avoidance dynamic sub-carrier allocation scheme for OFDM in the form of a Multiple-User Data-Enhanced Radio Server (MUDERS) application. This scheme designates useable sub-carriers using

information derived from a threshold-controlled periodogram monitoring the entire set of possible sub-carriers. One OFDM synchronisation symbol enables the crucial receiver tasks of frame synchronisation, carrier-frequency offset estimation and sub-carrier allocation notification to be achieved. Results presented in this paper show that the dynamic sub-carrier allocation significantly increases the data capacity and reduces the BER of received bits compared to a static OFDM implementation.

### REFERENCES

- [1] Cimini, L., Jr. "Analysis and Simulation of a Digital Mobile Channel Using Orthogonal Frequency Division Multiplexing." *Communications, IEEE Transactions on* [legacy, pre - 1988] (1985) 33(7): 665-675.
- [2] Weinstein, S. and P. Ebert (1971). "Data Transmission by Frequency-Division Multiplexing Using the Discrete Fourier Transform." *Communications, IEEE Transactions on* [legacy, pre - 1988] 19(5): 628-634.
- [3] IEEE Std 802.11a-1999, "Supplement to IEEE standard for information technology telecommunications and information exchange between systems - local and metropolitan area networks - specific requirements. Part 11: wireless LAN Medium Access Control (MAC) and Physical Layer (PHY) specifications: high-speed physical layer in the 5 GHz band".
- [4] IEEE Std 802.11g-2003, "IEEE standard for information technology-telecommunications and information exchange between systems- local and metropolitan area networks- specific requirements Part II: wireless LAN medium access control (MAC) and physical layer (PHY) specifications". IEEE Std 802.11g-2003 (Amendment to IEEE Std 802.11, 1999 Edn. (Reaff 2003) as amended by IEEE Stds 802.11a-1999, 802.11b-1999, 802.11b-1999/Cor 1-2001, and 802.11d-2001): i-67.
- [5] IEEE Std. 802.16-2001, "IEEE Standard for Local and Metropolitan area networks Part 16: Air Interface for Fixed Broadband Wireless Access Systems". IEEE Std 802.16-2001: pp: 1-322.
- [6] IEEE Std 802.16a-2003, "IEEE Standard for Local and metropolitan area networks — Part 16: Air Interface for Fixed Broadband Wireless Access Systems— Amendment 2: Medium Access Control Modifications and Additional Physical Layer Specifications for 2-11 GHz". IEEE Std 802.16a-2003 (Amendment to IEEE Std 802.16-2001) pp:1-292.
- [7] HIPERLAN type II, "HIPERLAN type 2 technical specification physical layer". Technical report, ETSI TS 101 475 V1.12.1A, June 2000.
- [8] ETSI DVB-T, "EN 300 744 v1.5.1 Digital Video Broadcasting (DVB); Framing Structure, Channel Coding and Modulation for Digital Terrestrial Television," Tech. Rep., June 2004.
- [9] ETSI EN 300 401 V1.3.3, "Radio Broadcasting Systems; Digital Audio Broadcasting (DAB) to mobile, portable and fixed receivers", May 2001.
- [10] ETSI ES 201 980 V.1.2.2, "Digital Radio Mondiale (DRM) System Specification", April 2003.
- [11] K. E. Nolan, "OFDM Sub-carrier Allocation Scheme for a Multiple User Data Enhanced Radio Server (MUDERS)," in *Proceedings of the 4th Software Defined Radio (SDR) Forum Technical Conference 2004*, Phoenix, Arizona, USA, 2004. vol. A, pp: 71-76.
- [12] Larsson, R., C. Ostberg, et al. (1996). Mixed traffic in a multi carrier system. Vehicular Technology Conference, 1996. 'Mobile Technology for the Human Race', IEEE 46th.
- [13] T. M. Cover and J. A. Thomas, *Elements of Information Theory* New York: Wiley, 1991.
- [14] Nallanathan, A. and C. L. Yun (2004). "Eigenbeam-space division multiplexing for OFDM systems with optimum resource allocation". Global Telecommunications Conference, 2004. GLOBECOM '04. IEEE.
- [15] P. Mackenzie, "Reconfigurable Software Radio Systems", *Ph.D dissertation*, Trinity College Dublin, Ireland, 2004.
- [16] Mackenzie, P., Nolan, K.E., Doyle, L., O'Mahony, D., "An architecture for the development of software radios on general purpose processors," in *Irish Signals and Systems Conference 2002*, 2002, pp. 275-280.
- [17] Schmidl, M. and D. C. Cox (1997). "Blind synchronisation for OFDM." *Electronics Letters* 33(2): 113-114.
- [18] Schmidl, T. M. and D. C. Cox (1996). "Low-overhead, low-complexity [burst] synchronization for OFDM". *Communications, 1996. ICC 96, Conference Record, Converging Technologies for Tomorrow's Applications*. 1996 IEEE International Conference on.